

FRONT PART RD 100

Planche N°1

Initial configuration of the machine at the exit of our workshops



PARTS LIST FIGURE N° 1 RD 100 UP - 2595		révisé le 04/09/2013	
REP	DESIGNATION	REFERENCES PIECES	
		RD 100	QTE
1	CONICAL BOLT	4000.1063	1
2	INERTIA WHEEL	5100.800.1004	1
3	HH SCREW M 10 - 30	850.2002	4
	WASHER W 10	695.1014	4
4	LEFT LIFT ARM	5100.760.D032	1
5	AXLE Ø19	120.1005	1
6	HH SCREW M 10 -25	850.2003	4
	WASHER W 10	695.1014	4
	WASHER MU 10	695.1017	4
7	GUARD CONE	093.1001	1
8	O-RING SEAL 73 X 3.5	400.1012	1
9	HSHC SCREW M 10 -25	850.3024	4
10	TRUMPET	095.1020	1
11	SECONDARY SHAFT	100.1001	1
12	BEARING 6209	690.1011	1
13	CIRCLIP 85 INT.	190.1007	1
14	CIRCLIP 45 EXT.	190.1003	2
15	LIP SEAL 45 X 85 X 10 DL	400.1001	1
16	SPACER BUSHING	139.1004	1
17	LINCH PIN Ø11	340.1001	2
18	DOUBLE AXLE 22 X 28	120.1006	2
19	HOOD	5100.770.1027	1
20	HH SCREW M 10 -25	850.2003	4
	HEX NUT M10	260.1011	4
	BLADE BOLT	4000.001	4
	HH SCREW M 10 -30	850.2002	2
	HEX NUT M10	260.1011	2
21	LEFT SIDE	5100.195.1001	1
22	CHAIN 38 LINKS - 31.75 PITCH	175.1001	1
23	CHAIN SPROCKET 13 TEETH	600.1001	1
24	CIRCLIP 40 EXT.	190.1001	1
25	CORK SEAL	420.1001	1
26	CHAIN CASE	180.1002	1
27	FILLER CAP	155.1003	1
28	HH SCREW M 10 -30	850.2002	1
	HEX NUT M10	260.1011	1
29	SHOE	5100.710.1001	1

Initial configuration of the machine at the exit of our workshops

PARTS LIST FIGURE N° 1 RD 100 UP - 2595		révisé le 04/09/2013	
REP	DESIGNATION	REFERENCES PIECES	
		RD 100	QTE
30	COPPER SEAL	410.1001	1
31	CHAIN CASE CAP	155.1002	1
32	HEX HEAD PLUG G 3/8	155.1001	1
33	HH SCREW M 8-30	850.2021	10
	HEX NUT M 8	260.1010	10
34	HH SCREW M 10 - 90	850.2001	1
	HEX NUT M10	260.1011	1
35	HH SCREW M 16-110	850.2010	1
	HEX NUT M 16	260.1015	1
36	HH SCREW M 16-50	850.1016	1
37	SHOCK ABSORBER MOUNTING	145.1002	1
38	BELLEVILLE WASHER	695.1032	2
39	FRONT CLUTCH PLATE	5130.250.1004	1
40	SPLINED BUSHING	140.1001	1
41	RING OF FRICTION D.U.	130.1001	1
42	CHAIN SPROCKET 16 TEETH	5100.600.1002	1
43	REAR CLUTCH PLATE	5130.250.1003	1
44	CIRCLIP 100 INT.	190.1006	1
45	HH SCREW M 12-60	850.2009	1
	HEX NUT M12	260.1012	1
	HEX NUT M12	260.1014	1
46	BEARING 6309 C3	690.1003	1
47	HH SCREW M 16-80	850.1015	1
	HEX NUT M 16	260.1016	1
48	SPRING	660.1005	1
49	CHAIN TENSIONER	5100.730.1001	1
50	LIP SEAL 54 X 72 X 10 DL	400.1005	1
51	HH SCREW 1/2 - 43	850.1003	6
	HEAVY HEX NUT 1/2	260.1002	6
52	FELT SEAL	415.1001	1
53	ELBOW UNION G 13-8X13	265.1002	1
54	DRIVE PLATE	5100.630.1005	1
55	HH SCREW M 12-80	850.2014	2
	HEX NUT M12	260.1014	2
56	LEFT BLADE	450.1002	18
57	RIGHT BLADE	450.1001	18
58	BLADE BOLT	4000.001	76

Initial configuration of the machine at the exit of our workshops

PARTS LIST FIGURE N° 1 RD 100 UP - 2595		révisé le 04/09/2013	
REP	DESIGNATION	REFERENCES PIECES	
		RD 100	QTE
59	GRID FINGER	210.1001	36
60	FINGERS CLAMP	150.1001	9
61	HSHC SCREW M 10 -35	850.3002	35
	HEX NUT M10	260.1011	35
62	GRID	5100.770.1014	1
63	ROTOR	5100.760.1002	1
64	SMALL PLATE	5150.630.1003	1
65	HH SCREW 1/2 - 38	850.1002	6
	HEAVY HEX NUT 1/2	260.1002	6
66	RIGHT SIDE	5100.195.1002	1
67	LIP SEAL 40 X 58 X 10 DL	400.1002	1
68	BEARING 22206	690.1017	1
69	WASHER 30 * 40 * 2	695.1028	1
70	CIRCLIP 30 EXT.	190.1002	1
71	CAP	178.1004	1
72	HSHC SCREW M 8 - 25	850.3003	3
73	HEX HEAD PLUG G 3/8	155.1001	1
74	REAR FLAP	770.1015	1
75	HH SCREW M 12-130	850.2013	2
	HEX NUT M12	260.1012	2
76	GRID HINGE	5100.240.1005	2
77	HH SCREW M 12-25	850.1010	4
	HEX NUT M12	260.1012	4
78	COMPLETE TRANSFER CASE	095.1002	1
79	HH SCREW M 12-30	850.2016	4
	WASHER W 12	695.1019	4
80	3-POINT HITCH	5100.750.1041	1
81	RIGHT LIFT ARM	5100.760.D032	1
82	HH SCREW M 10 -75	850.1013	2
	HEX NUT M10	260.1011	2
83	LINCH PIN Ø11	340.1004	1

CASE SET RD 100

Figure N°2

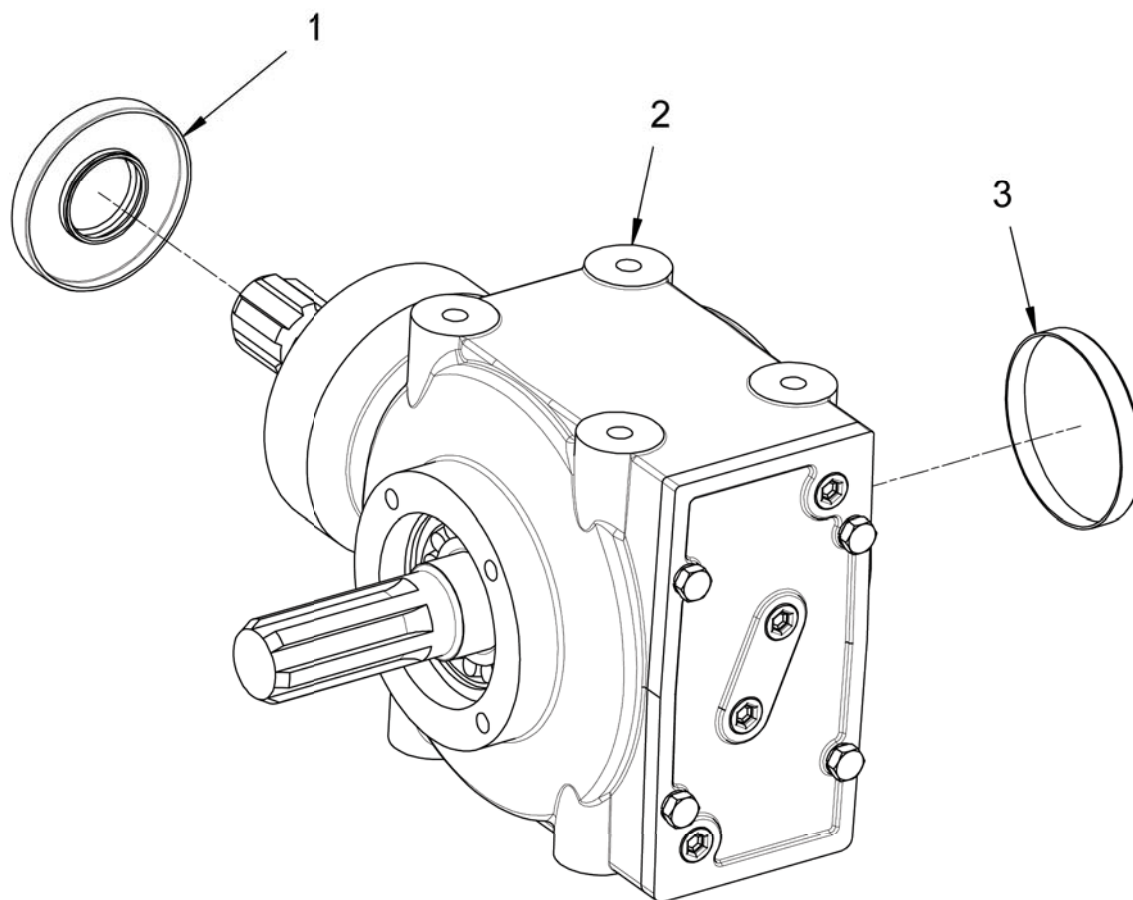

*Initial configuration of
the machine at the exit
of our workshops*



**DAIRON
S.A.S**

Since 1958

DAIRON S.A.S. D92 Les Hunaudières
72230 MULSANNE
☎ 02 43 422 422 Fax. 02 43 422 000
E-mail. Rotadairon@wanadoo.fr

		PARTS LIST FIGURE N° 2 RD 100 UP - 2595		révisé le 04/09/2013
REP	DESIGNATION	REFERENCES PIECES		
		RD 100	QTE	
1	LIP SEAL Ø 80/Ø 35/ 10 DL	400-1016	1	
2	COMPLETE TRANSFER CASE	095-1002	1	
3	COVER Ø 80 x 10	400-1017	1	

MD FRAME RD 100

Figure N°3

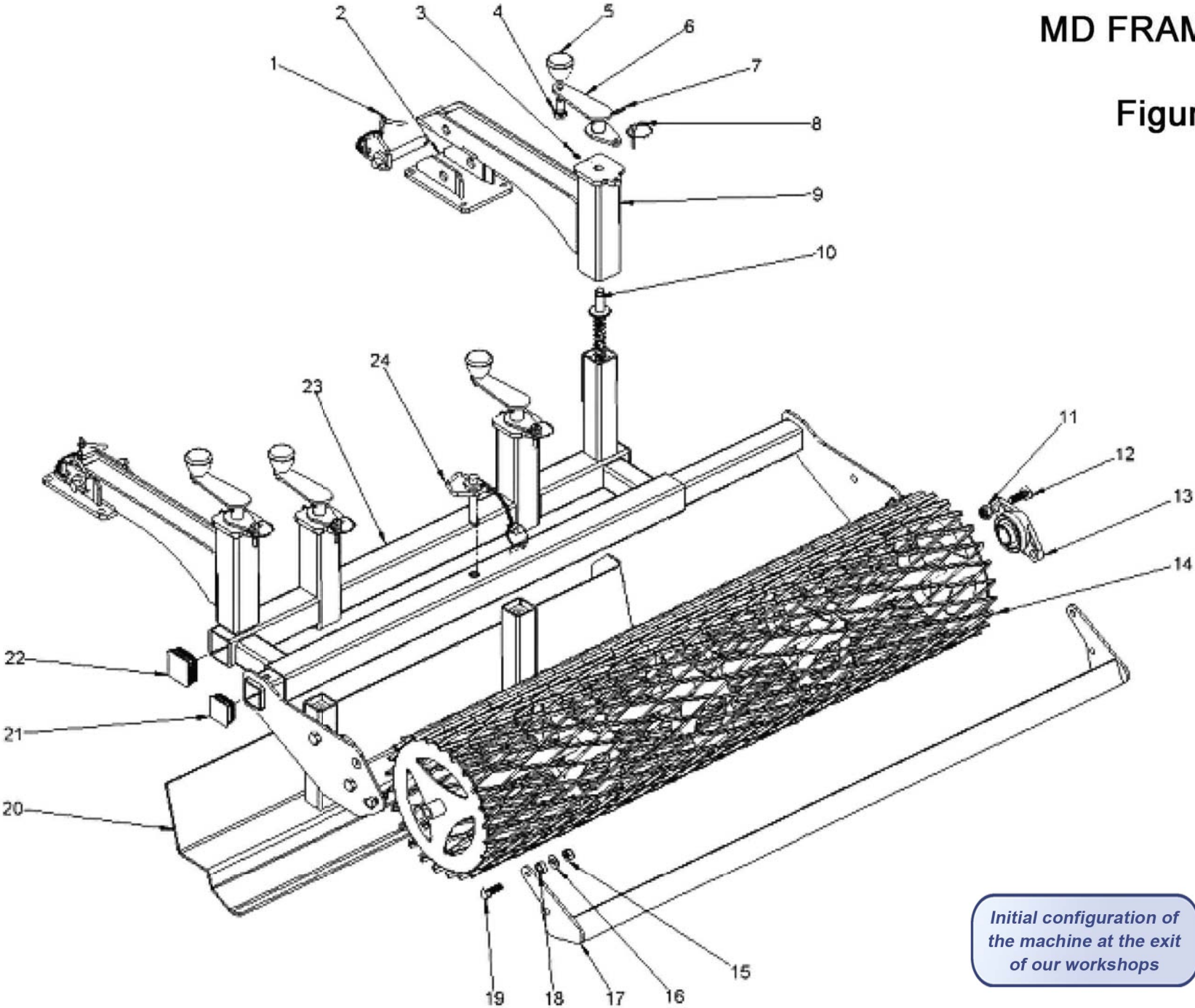

Initial configuration of the machine at the exit of our workshops



PARTS LIST FIGURE N° 3 RD 100 UP - 2595		révisé le 04/09/2013	
REP	DESIGNATION	REFERENCES PIECES	
		RD 100	QTE
1	HITCH PIN WITH HANDLE Ø19 L 115	151.1002	2
2	ARM BRACKET	5100.270.1005	2
3	OILER M8	320.1001	4
4	HH SCREW M 14-30	850.2005	4
5	CRANK HANDLE M14	610.1001	4
6	CRANK	5100.640.1001	4
7	DOWEL PIN Ø 6 X 25	340.1007	4
8	LINCH PIN Ø6	340.1005	4
9	FRAME ARM	5100.270.1004	2
10	FRAME SCREW	5100.850.1039	4
11	HEX NUT M14	260.1013	4
12	HH SCREW M 14-35	850-2019	4
13	CAST IRON BEARING HOUSING UCFL 206	690.1021	2
14	ROLLER	5100.505.1003	1
15	HEX NUT M 12	260.1012	4
16	WASHER MU 12	695.1018	4
17	SCRAPER	5100.725.1001	1
18	SOCKET	240.1030	2
19	HH SCREW M 12-35	850.2018	4
20	LEVELLING BLADE	5100.450.1009	1
21	PLASTIC CAP 50 x 50	156.1001	2
22	PLASTIC CAP 60 x 60	156.1002	2
23	FRAME	5100.750.1001	1
24	HITCH PIN WITH HANDLE Ø19 L 90	151.1001	1

Remplacement du repère N°1

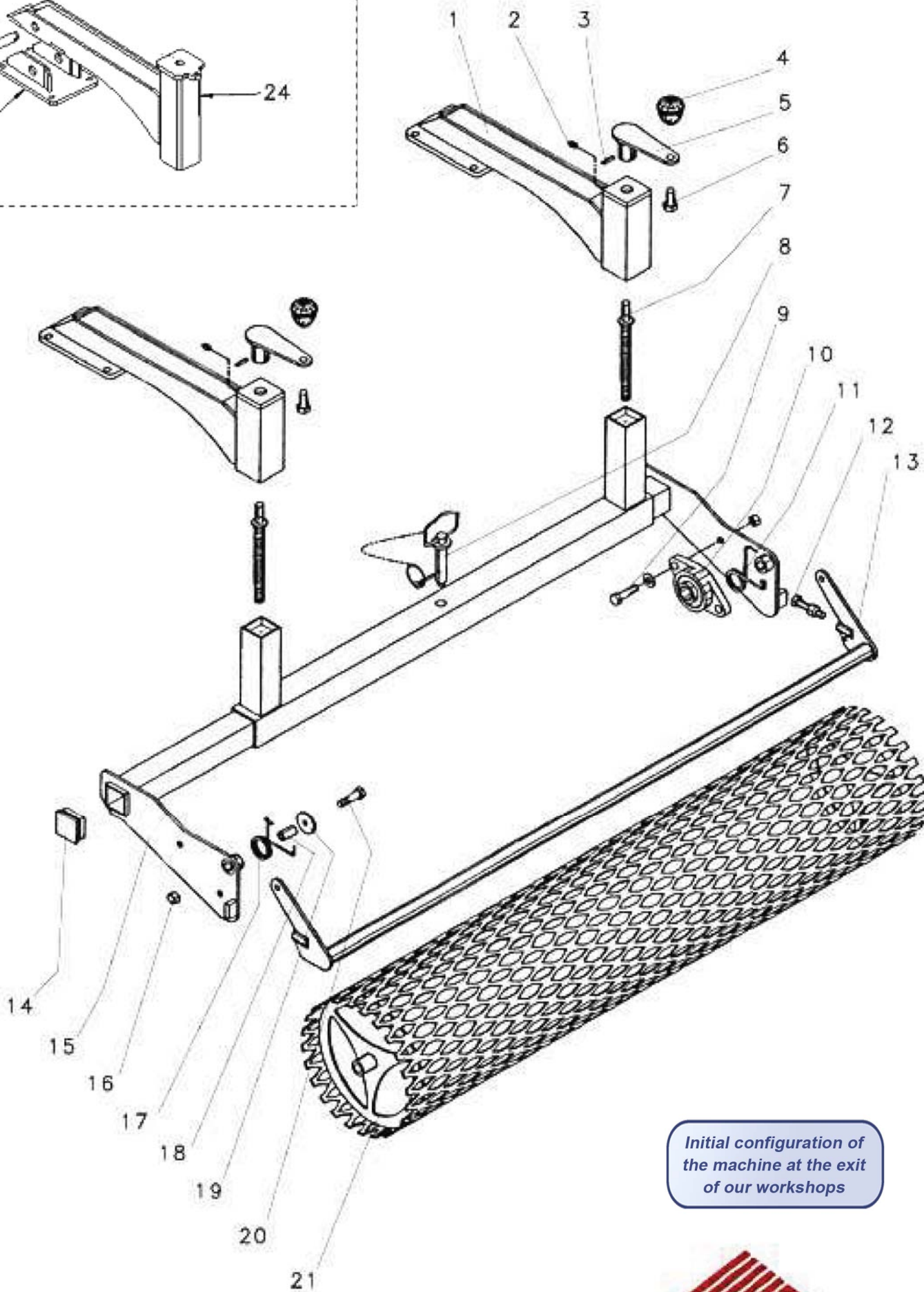
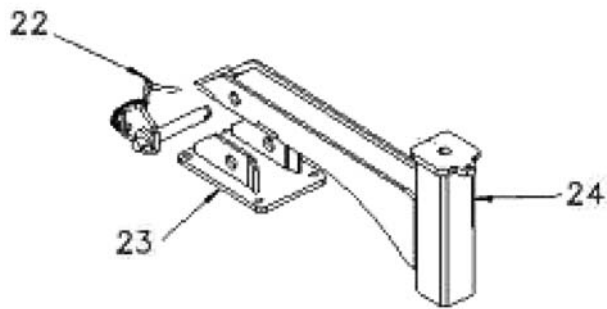

Initial configuration of the machine at the exit of our workshops

Planche N°4

CHASSIS ROULEAU

RD100.



PARTS LIST FIGURE N° 4 RD 100 UP - 2595		révisé le 04/09/2013	
REP	DESIGNATION	REFERENCES PIECES	
		RD 100	QTE
1	FRAME ARM		
2	OILER M8	320.1001	2
3	DOWEL PIN Ø 6 X 25	340.1007	2
4	CRANK HANDLE M14	610.1001	2
5	CRANK	5100.640.1001	2
6	HH SCREW M 14-30	850.2005	2
7	FRAME SCREW	5100.850.1039	2
8	HITCH PIN WITH HANDLE Ø19 L 90	151.1001	1
9	HH SCREW M 14-35	850.2019	4
	HEX NUT M14	260.2013	4
10	CAST IRON BEARING HOUSING UCFL 206	690.1021	2
11	RIGHT SPRING	660.1002	1
12	HH SCREW M 12-80	850.2014	2
	HEX NUT M12	260.1014	2
13	SCRAPER	5100.725.1001	1
14	PLASTIC CAP 50 x 50	156.1001	2
15	FRAME	5100.750.1001	1
16	HEX NUT M10	260.1011	2
17	SPRING LEFT	660.1003	1
18	SOCKET	240.1022	2
19	WASHER	695.1029	2
20	HH SCREW M 10-45	850.2008	2
21	ROLLER	5100.505.1003	1
22	HITCH PIN WITH HANDLE Ø19 L 115	151.1002	2
23	ARM BRACKET	5100.270.1005	2
24	FRAME ARM	5100.270.1004	2