

Initial configuration of the machine at the exit of our workshops

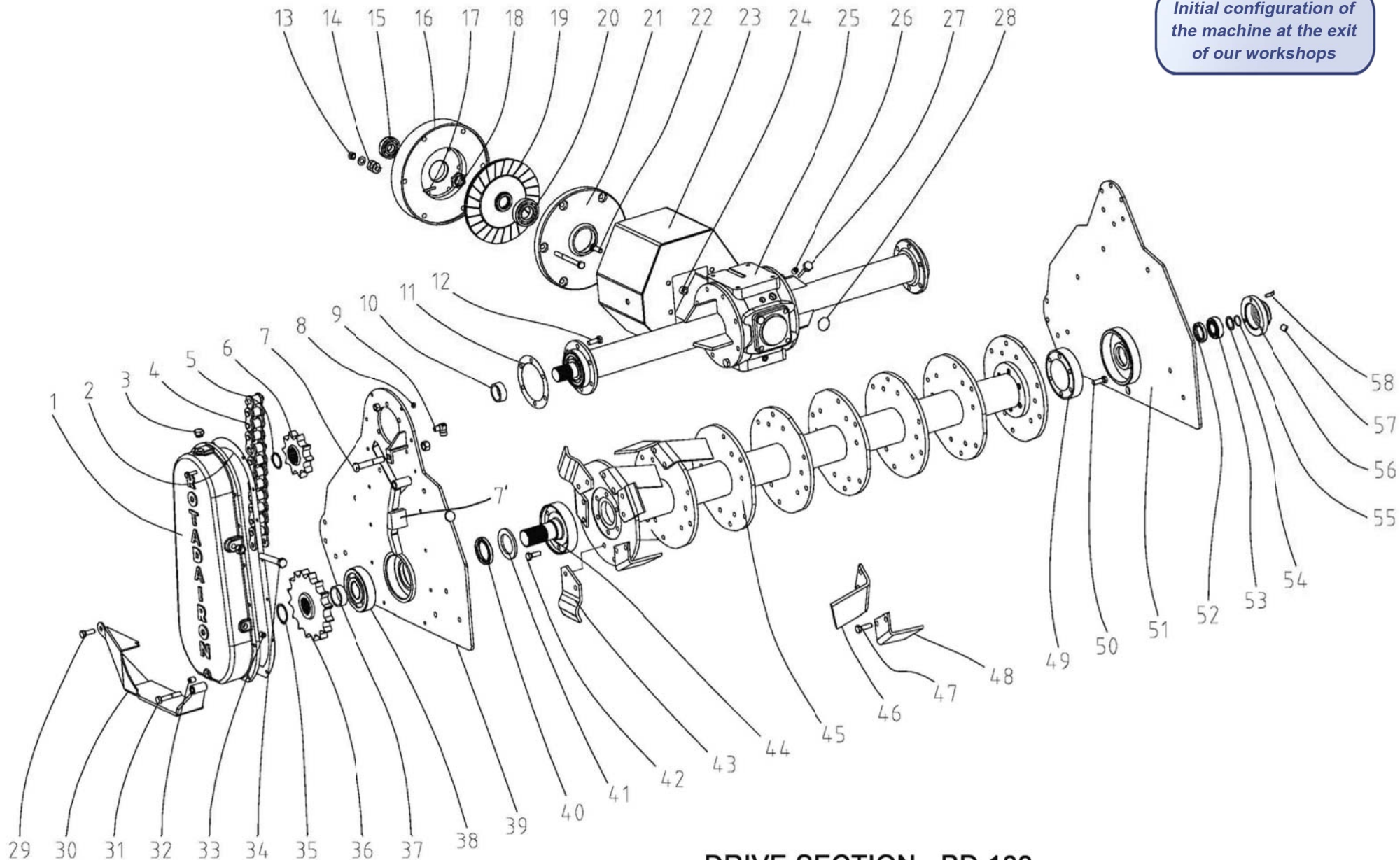

DRIVE SECTION RD 180

Figure N°1

PARTS LIST FIGURE N° 1 RD 150 UP - 623			
ITEM	DESIGNATION	PARTS REFERENCES	
		RD 180	QTY
1	CHAIN CASE	180.1003.	1
2	CORK SEAL	420.1002.	1
3	FILLER CAP	155.1003.	1
4	CHAIN 38 LINKS - 38.1 PITCH	175.1002.	1
5	CIRCLIP 45 EXT.	190.1003.	1
6	CHAIN SPROCKET 10T - 38.1 PITCH	600.1008.	1
7	HH SCREW M 16-90	4000.1039.	1
7'	CHAIN TENSIONER	5150.730.1004	1
8	HH SCREW M 8-35	4000.005.	14
9	ELBOW UNION G 13-8X13	265.1002.	1
10	SPACER BUSHING	139.1005.	1
11	PAPER GASKET	415.1002.	1
12	HH BOLT M 12-35	4000.1018.	12
13	CLUTCH NUTTED BOLT	4000.1022.	6
14	CLUTCH SPRING	660.1004.	6
15	BEARING 6305 2RS	690.1006.	1
16	FRONT FLYWHEEL	800.1002.	1
17	DOWEL PIN Ø6 - 40	340.1009.	1
18	HEX NUT M 30 X 200	260.1007.	1
19	CLUTCH PLATE	5150.257.1001.	1
20	BEARING 6208 2RS	690.1005.	1
21	REAR FLYWHEEL	800.1001.	1
22	HH SCREW M 12-50	850.2012.	4
23	CACHE VOLANT	5150.640.1008.	1
24	SOCKET	240.1031.	4
25	COMPLETE TRANSFER CASE + TRUMPET	5180.180.1007.	1
26	SNIFTER VALVE G 1/8	670.1002.	1
27	DIPSTICK	390.1001	1
28	BLANKING CAP	156.1005.	1
29	HH BOLT M 12-35	4000.1018.	1
30	SHOE	5150.710.1002.	1
31	HH BOLT M 12-70	4000.008.	1
32	HEX HEAD PLUG G 3/8	155.1001.	1
33	HEX HEAD PLUG G 3/8	155.1001.	1
34	HH BOLT M 16-110	4000.1014.	1
35	CIRCLIP 50 EXT.	190.1004.	1
36	CHAIN SPROCKET 16T - 38.1 PITCH	600.1007.	1
37	SPACER BUSHING	139.1006.	1

Initial configuration of the machine at the exit of our workshops

PARTS LIST FIGURE N° 1 RD 150 UP - 623			
ITEM	DESIGNATION	PARTS REFERENCES	
		RD 180	QTY
38	BEARING 6410	690.1009.	1
39	LEFT SIDE	5150.195.1003.	1
40	SEALING RING Ø60 / Ø80 / 10	400.1005.	1
41	FELT SEAL	415.1001.	1
42	HSHC SCREW M 12 -35	850.3015.	6
43	S BLADE	450.1005.	6
44	DRIVE PLATE	5150.630.1001.	1
45	ROTOR	5180.760.1004.	1
46	LEFT BLADE 90 X 8	450.1004.	24
47	BLADE BOLT	4000.002.	108
48	RIGHT BLADE 90 X 8	450.1003.	24
49	SMALL PLATE	5150.630.1003.	1
50	HSHC SCREW M 12 - 30 YZP	850.3019.	6
51	RIGHT SIDE	5180.195.1005.	1
52	LIP SEAL 40 X 58 X 10 DL	400.1002.	1
53	BEARING 22206	690.1017.	1
54	WASHER 30 * 40 * 2	695.1028.	1
55	CIRCLIP Ø 30 EXT.	190.1002.	1
56	CAP	178.1004.	1
57	HEX HEAD PLUG G 3/8	155.1001.	1
58	HSHC SCREW M 8 - 25	850.3003.	3



Initial configuration of
the machine at the exit
of our workshops

TRANSFER CASE + TRUMPET RD 180

Figure N°2

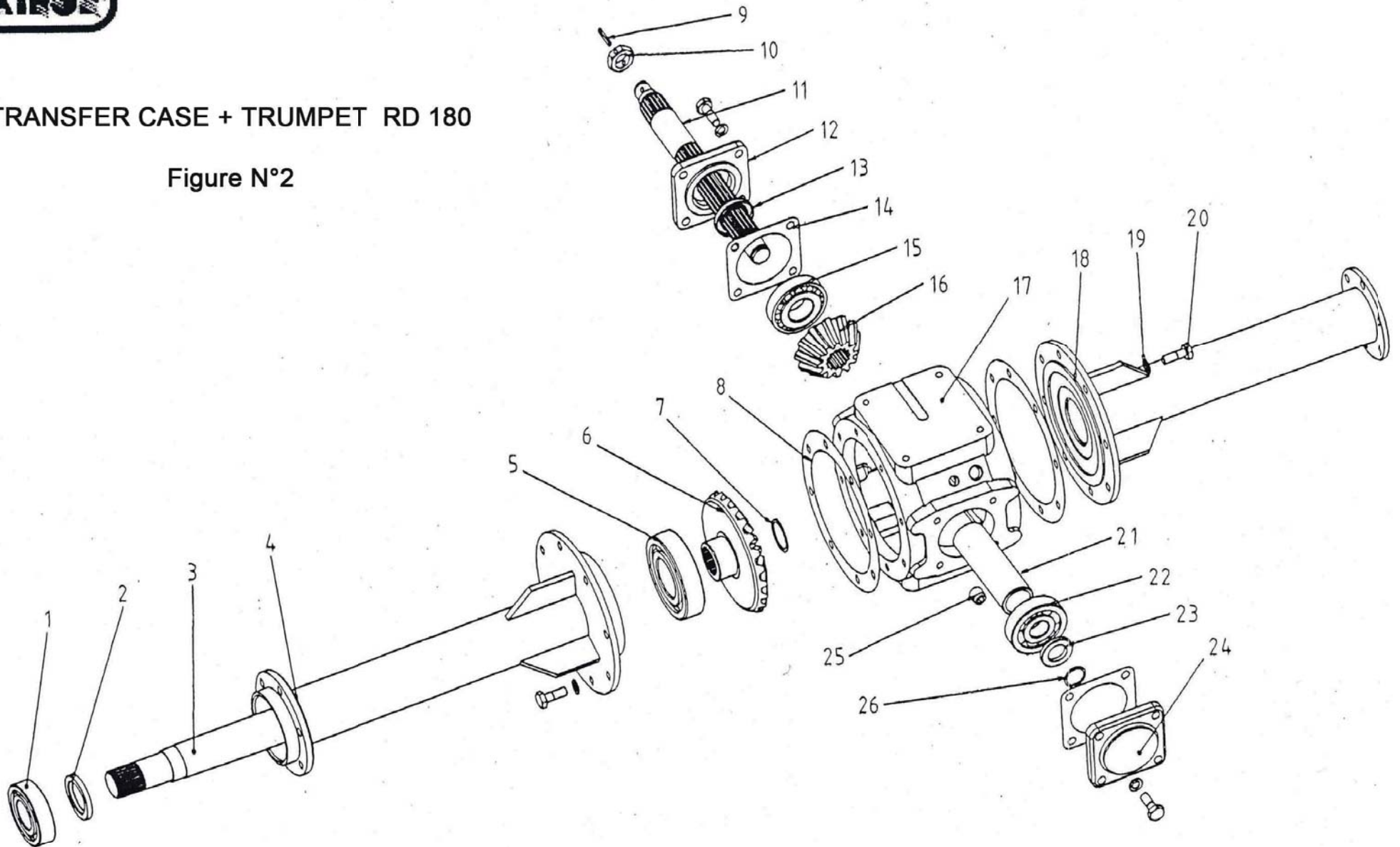

PARTS LIST FIGURE N° 2 RD 150 UP - 623			
ITEM	DESIGNATION	PARTS REFERENCES	
		RD 180	QTY
1	BEARING 6309 C3	690.1003.	1
2	SEALING RING Ø50/Ø72/10	400.1004.	1
3	SECONDARY SHAFT	100.1011.	1
4	LEFT TRUMPET	5180.760.1027.	1
5	BEARING 6312	690.1010.	1
6	BEVEL GEAR 23T	600.1006.	1
7	CIRCLIP 45 EXT.	190.1003.	1
8	PAPER GASKET	415.1003.	2
9	DOWEL PIN Ø6 - 40	340.1009.	1
10	HEX NUT M 30 X 200	260.1007.	1
11	INPUT SHAFT	55150.100.1003.	1
12	FRONT COVER	178.1001.	1
13	LIP SEAL 40, 62,10 DL	400.1003.	1
14	PAPER GASKET	415.1008.	2
15	BEARING 30308	690.1014.	1
16	BEVEL GEAR 12T	600.1003.	1
17	TRANSFER CASE	180.1007.	1
18	RIGHT TRUMPET	5180.760.1036.	1
19	WASHER W 12 ,YZP	695.1019.	24
20	HH SCREW M 12-35	850.2018.	24
21	SPACER BUSHING	139.1007.	1
22	BEARING 6406	690.1007.	1
23	INPUT SHAFT WASHER	695.1046.	1
24	BACK COVER	178.1005.	1
25	HEX HEAD PLUG G 1/2	155.1005.	1
26	CIRCLIP 30 EXT.	190.1002.	1

HOOD SECTION RD 180

Figure N°3

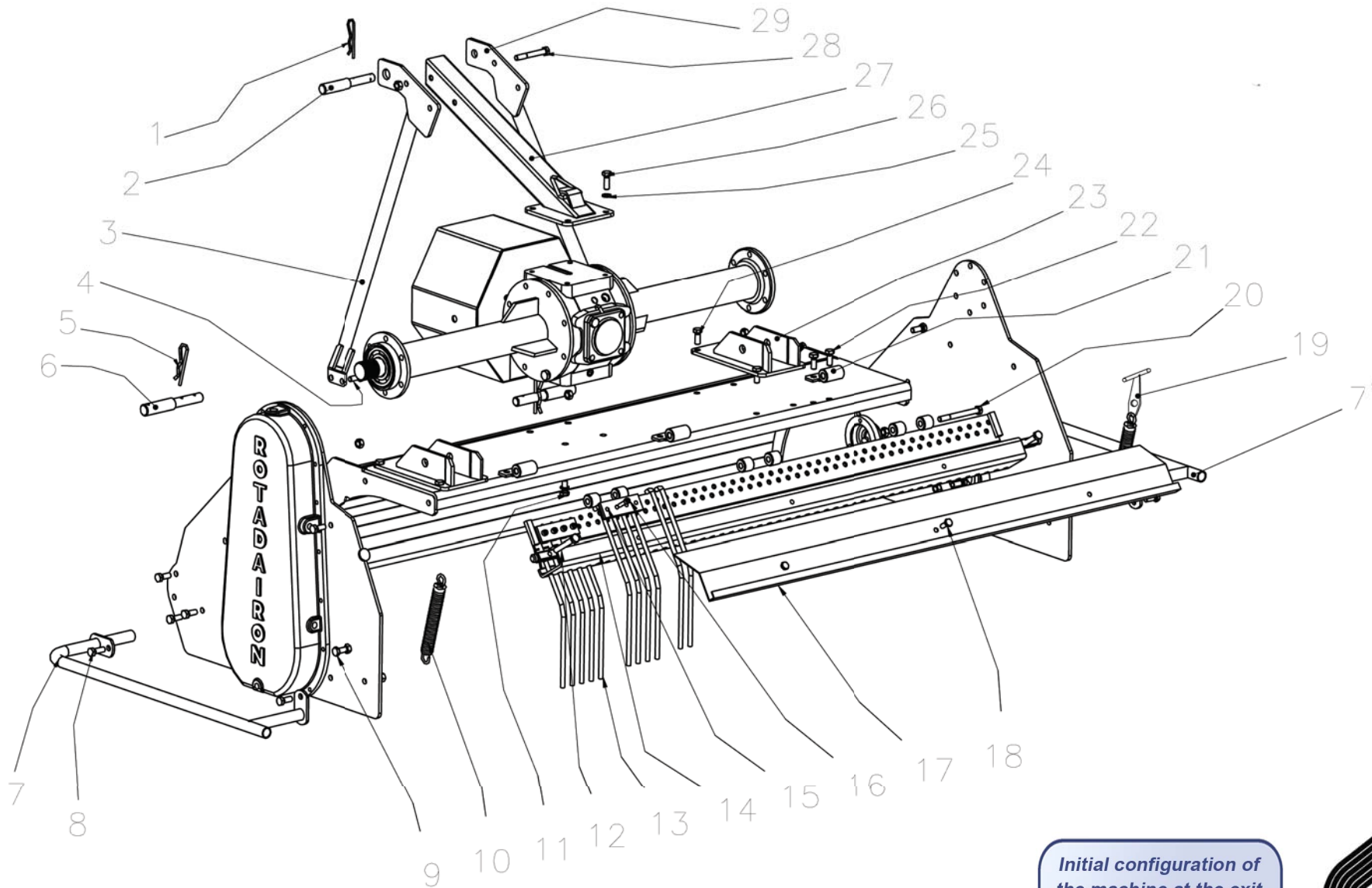

Initial configuration of the machine at the exit of our workshops

PARTS LIST FIGURE N° 3 RD 150 UP - 623			
ITEM	DESIGNATION	PARTS REFERENCES	
		RD 180	QTY
1	R-CLIP RETAINING PIN Ø4.5	340.1003	1
2	DOUBLE AXLE 19 X 25	120.1001	1
3	LEFT LIFT ARM	5150.760.G018	1
4	HH SCREW M 12-30	850.2016	4
	HEX NUT M12	260.1012	4
5	R-CLIP RETAINING PIN Ø6	340.1001	2
6	DOUBLE AXLE 22 X 28	120.U002	2
7	LEFT SIDE GUARD	5150.760.G023	1
7'	RIGHT SIDE GUARD	5150.760.D023	1
8	HH SCREW M 12-30	850.2016	4
	HEX NUT M12	260.1012	4
9	HH SCREW M 12-60	850.2009	2
	HEX NUT M12	260.1012	2
	HEX NUT M12	260.1014	2
10	SPRING	660.1005	2
11	HH SCREW M 12-35	850.2018	4
	WASHER W 12 YZP	695.1019	4
12	HH SCREW M 12-80	850.2018	2
	HEX NUT M12	260.1014	2
13	GRID FINGER	210.1002	58
14	GRID PLATE	5180.770.1020	1
15	GRID CLAMP	150.1001	14,5
16	HS HC SCREW M 10 -30	850.3002	59
	HEX NUT M10	260.1011	59
17	REAR FLAP	770.1021	1
18	HH SCREW M 10 -25	850.2003	4
	WASHER MU 10 YZP	695.1017	4
19	SPRING HANDLE	5075.620.1019	2
20	HH SCREW M 12-130	850.2013	4
	HEX NUT M12	260.1012	4
21	GRID HINGE	5100.240.1005	4
22	HH SCREW M 12-30	850.2016	8
	HEX NUT M12	260.1012	8
23	ARM BRACKET	5150.640.1006	2
24	HH SCREW M 12-30	850.2016	8
	HEX NUT M12	260.1012	8
25	HH SCREW M 12-35	850.2018	4
26	WASHER W 12 YZP	695.1019	4

Initial configuration of the machine at the exit of our workshops

PARTS LIST FIGURE N° 3 RD 150 UP - 623			
ITEM	DESIGNATION	PARTS REFERENCES	
		RD 180	QTY
27	MAIN HITCH POINT	5150.750.1091	1
28	HH SCREW M 12-90	850.1021	2
	HEX NUT M12	260.1012	2
29	RIGHT LIFT ARM	5150.760.D018	1