

Initial configuration of the machine at the exit of our workshops

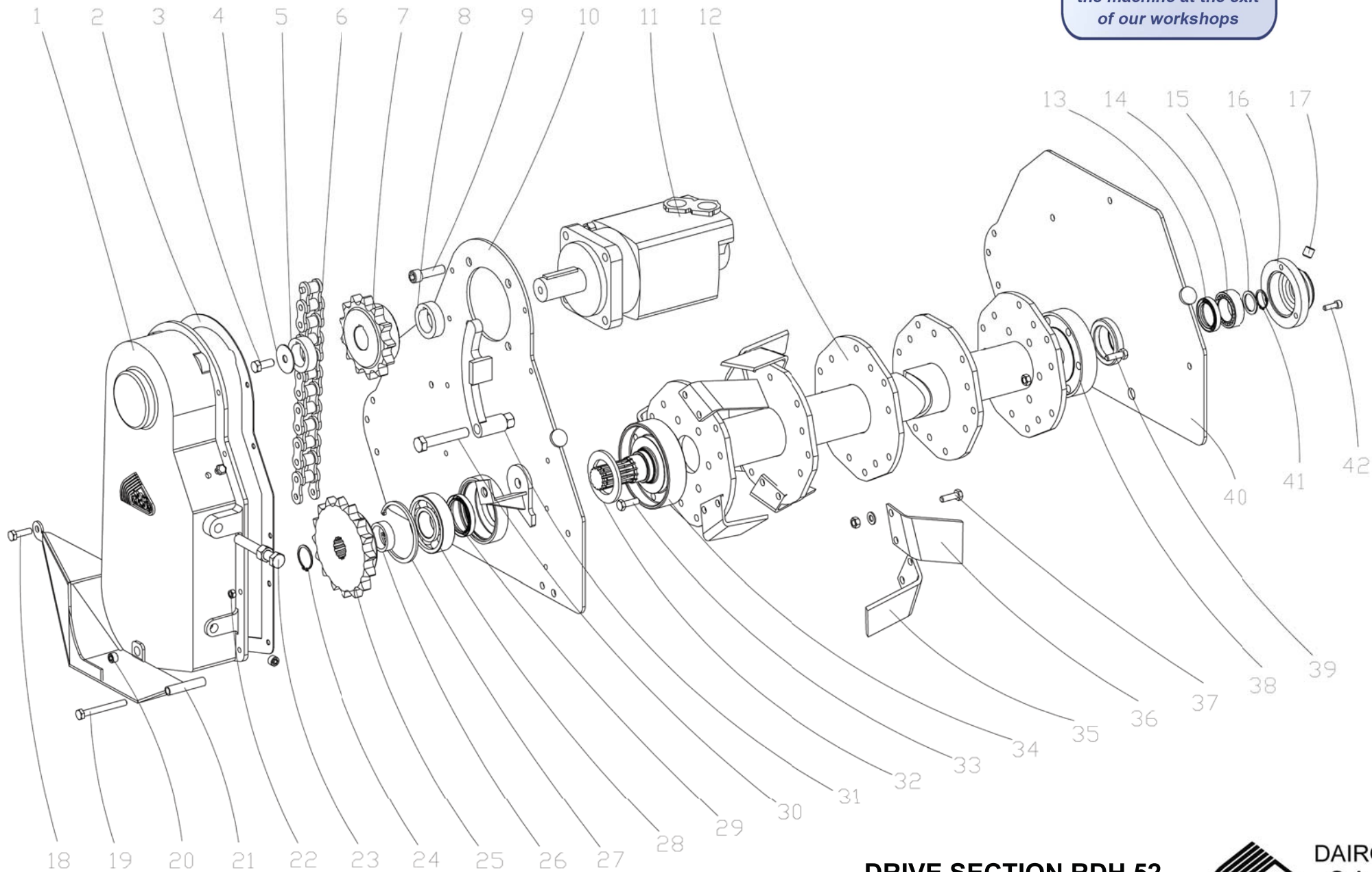

**DRIVE SECTION RDH 52**

Figure N°1

PARTS LIST FIGURE N° 1 RDH 52 UP - 5589			
ITEM	DESIGNATION	PARTS REFERENCES	
		RDH 52	QTY
1	CHAIN CASE	180.1009	1
2	CORK SEAL	420.1001	1
3	HH SCREW M 12-30	850.2016	1
4	WASHER	695.1051	1
5	SPACER SLEEVE	240.1025	1
6	CHAIN 38 LINKS - 31.75 PITCH	175.1001	1
7	CHAIN SPROCKET 13T	600.1026	1
8	SPACER SLEEVE	240.1025	1
9	HSHC SCREW M 14 - 50	850.3005	4
	HEX NUT M 14	260.1013	4
10	LEFT SIDE	5060.195.1013	1
11	HYDRAULIC MOTOR	SEE FIGURE N°4	
12	ROTOR	5052.760.1003	1
13	LIP SEAL 40 X 58 X 10 DL	400.1002	1
14	BEARING 22206	690.1017	1
15	WASHER 30 * 40 * 2	695.1028	1
16	CAP	178.1004	1
17	HEX HEAD PLUG G 3/8	155.1001	2
18	HH SCREW M 10-35	850.2022	1
	HEX NUT M 10	260.1011	1
19	HH SCREW M 10 - 90	850.2001	1
	HEX NUT M 10	260.1011	1
20	HEX HEAD PLUG G 3/8	155.1001	1
21	SHOE	5100.710.1001	1
22	HH SCREW M 8-30	850.2021	10
	HEX NUT M 8	260.1010	10
23	HH SCREW M 16-110	850.2010	1
	HEX NUT M 16	260.1015	1
24	CIRCLIP Ø 40 EXT.	190.1001	1
25	CHAIN SPROCKET 16T	600.1025	1
26	SPACER BUSHING	139.1002	1
27	CIRCLIP Ø 100 INT.	190.1006	1
28	BEARING 6309 C3	690.1003	1
29	LIP SEAL 54 X 72 X 10 DL	400.1005	1

Initial configuration of the machine at the exit of our workshops

PARTS LIST FIGURE N° 1 RDH 52 UP - 5589			
ITEM	DESIGNATION	PARTS REFERENCES	
		RDH 52	QTY
30	HH SCREW M 16-80	850.1015	1
	HEX NUT M 16	260.1016	1
31	CHAIN TENSIONER	5100.730.1001	1
32	FELT SEAL	415.1001	1
33	HH SCREW 1/2 - 43	850.1003	6
	HEAVY HEX NUT 1/2	260.1002	6
34	DRIVE PLATE	5060.630.1009	1
35	LEFT BLADE	450.1002	14
36	RIGHT BLADE	450.1001	14
37	BLADE BOLT	4000.001	56
38	SMALL PLATE	5150.630.1003	1
39	HH SCREW 1/2 - 38	850.1002	6
	HEAVY HEX NUT 1/2	260.1002	6
40	RIGHT SIDE	5100.195.1002	1
41	CIRCLIP Ø 30 EXT.	190.1002	1
42	HSHC SCREW M 8 - 25	850.3003	3

# MD FRAME RDH 60

Figure N°2

*Initial configuration of the machine at the exit of our workshops*

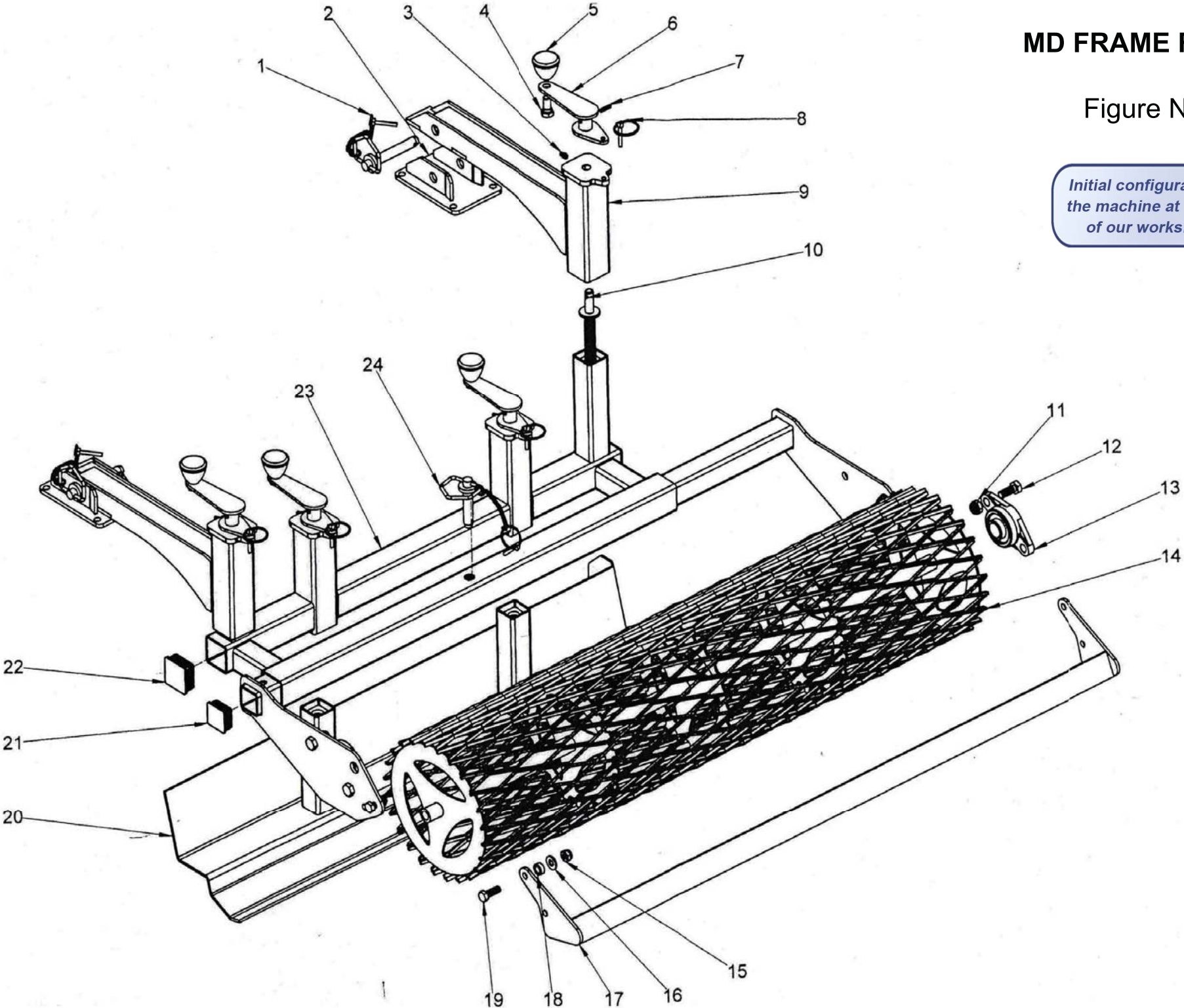

PARTS LIST FIGURE N° 2 RDH 52 UP - 5589			
ITEM	DESIGNATION	PARTS REFERENCES	
		RDH 52	QTY
1	HITCH PIN WITH HANDLE Ø19 L 90	151.1001	2
2	ARM BRACKET	5100.270.1005	2
3	OILER M8	320.1001	4
4	HH SCREW M 14-30	850.2005	4
5	CRANK HANDLE M 14	610.1001	4
6	CRANK	5100.640.1001	4
7	DOWEL PIN Ø6 X 25	340.1007	4
8	LINCH PIN Ø6	340.1005	4
9	FRAME ARM	5100.270.1004	2
10	FRAME SCREW	5100.850.1039	4
11	HEX NUT M 14	260.1013	4
12	HH SCREW M 14-35	850.2019	4
13	CAST IRON BEARING HOUSING UCFL 206	690.1021	2
14	MD ROLLER	5130.505.1004	1
15	HEX NUT M 12	260.1012	4
16	WASHER MU 12	695.1018	4
17	SCRAPER	5130.725.1002	1
18	SOCKET	240.1030	2
19	HH SCREW M 12-35	850.2018	4
20	LEVELLING BLADE	5052.450.1010	1
21	PLASTIC CAP 50 x 50	156.1001	2
22	PLASTIC CAP 60 x 60	156.1002	2
23	MD FRAME	5052.750.1078	1
24	HITCH PIN WITH HANDLE Ø19 L 90	151.1001	1



# HOOD SECTION RDH 60

Figure N°3

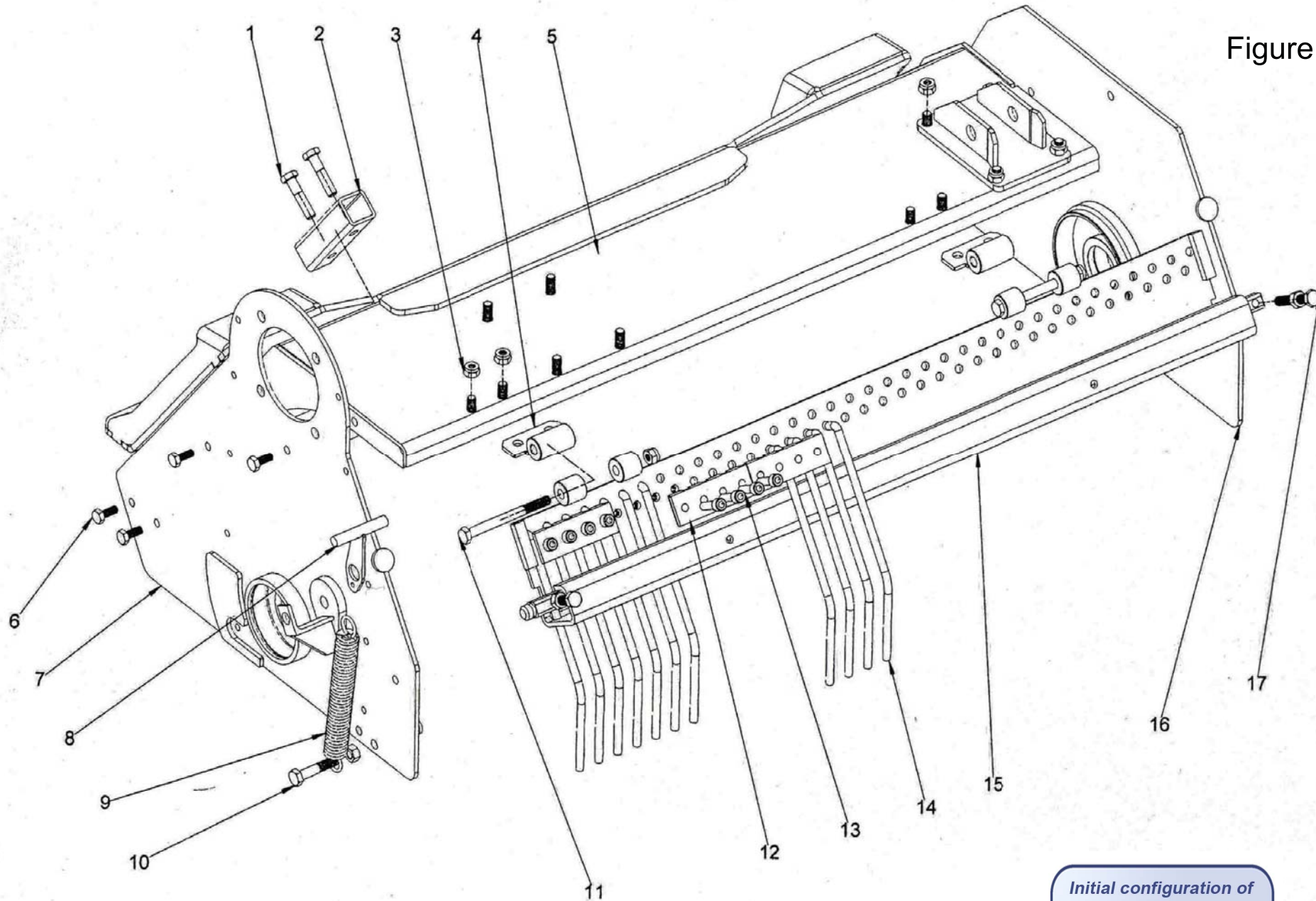

*Initial configuration of the machine at the exit of our workshops*



PARTS LIST FIGURE N° 3 RDH 52 UP - 5589			
ITEM	DESIGNATION	PARTS REFERENCES	
		RDH 52	QTY
1	HH SCREW 1/2 * 2" 3/4	/	0
2	TUBE OF FIXING	/	0
3	HEX NUT M 12	260.1012	8
4	GRID HINGE	5100.240.1005	3
5	HOOD	5052.770.1106	1
6	HH SCREW 10 - 30	850.2002	4
	HEX NUT M 10	260.1011	1
	BLADE BOLT	4000.001	4
7	LEFT SIDE	5060.195.1013	1
8	SPRING HANDLE	5075.620.1019	1
9	SPRING	660.1005	1
10	HH SCREW M 12-60	850.2009	1
	HEX NUT M 12	260.1012	1
	HEX NUT M 12	260.1014	1
11	HH SCREW M 12-130	850.2013	3
	HEX NUT M 12	260.1012	3
12	GRID CLAMP	150.1001	11
13	HSHC SCREW M 10 -35	850.3002	43
	HEX NUT M 10	260.1011	43
14	GRID FINGER	210.1001	44
15	GRID	5052.770.1108	1
16	RIGHT SIDE	5100.195.1002	1
17	HH SCREW M 12-80	850.2014	2
	HEX NUT M 12	260.1014	2

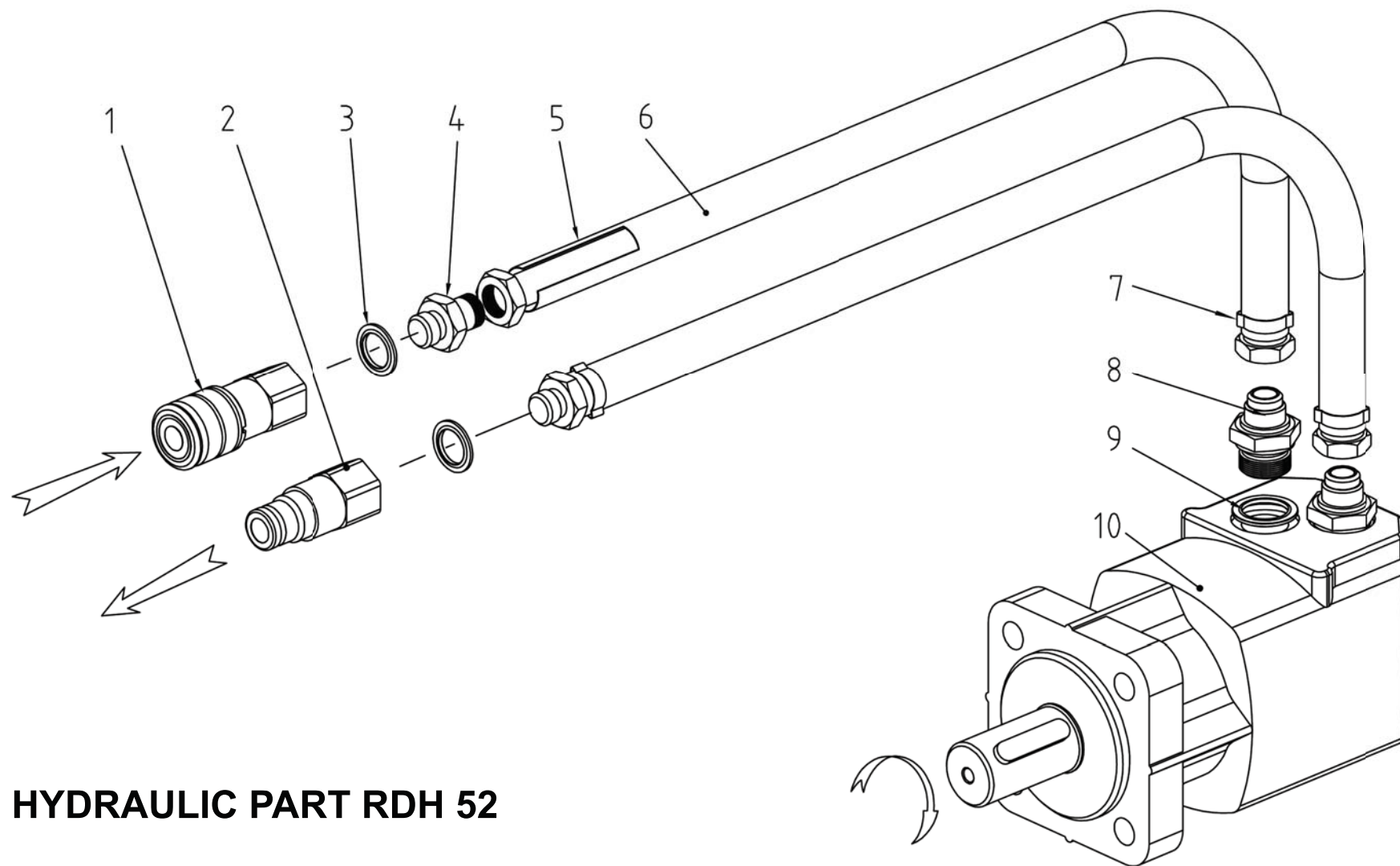

**HYDRAULIC PART RDH 52**

Figure N°4

*Initial configuration of the machine at the exit of our workshops*



PARTS LIST FIGURE N° 4 RDH 52 UP - 5589			
ITEM	DESIGNATION	PARTS REFERENCES	
		RDH 52	QTY
1	FEMALE COUPLER ANTIPOLLUTION	360-1006	1
2	MALE COUPLER ANTIPOLLUTION	360-1005	1
3	COMPOSITE SEAL 27	360-1008	2
4	ADAPTOR	360-1007	2
5	PROTECTIVE SHEATH	360-1010	2
6	HOSE	360-1076	2
7	NECKLACE WITH EARS	360-1011	4
8	ADAPTOR	360-1012	2
9	COMPOSITE SEAL 33	360-1013	2
10	HYDRAULIC MOTOR	360-1001	1